

PV - Solar photovoltaic diesel hybrid system in Malaysia

Type of project: (tick off the type)	PV	Solar Thermal	Biomass to Energy		
	x				
Project name:	Solar photovoltaic diesel hybrid system				
Location of the plant:	Nature Education and Research Center (NERC) at Endau Rompin National Park, Johor, Malaysia				
Year of Implementation:	1998				
Operator: (Name and address)	Staff of NERC				
Planner: (Name and address)	Local company				
Detailed description of the installation: (technology, function, benefit for users, etc. max 150 words)	<p>The system uses 112 modules giving a peak capacity of 10.08 KWp. The operating voltage is 48 VDC. There are 24 battery cells at 1525 Ah per cell and the diesel generator rating at 7.5 KVA. The system designed using a 74:26 ratio between solar and diesel contribution in terms of energy requirements. Accompanying equipments include two 100 A charge controllers and two 3.5 KVA inverters.</p> <p>The load of the NERC includes power for residential type electrical equipments, such as lights, TV, radio, freezer, refrigerator and computers accounting for 27.4 KWh per day.</p>				
Generated Energy service: (tick off the energy type)	electricity	heat	gas	Light	
	x				
Power output of installation: (kWel, m ³ biogas, kW th, etc.)	17,479 KWh per year				
Financing (tick off the financing type)	private investment	loan	donation	grant	
	x		X		
Investment costs in US\$	630,710.80 RM (approx. 165,990 US\$)				
Maintenance costs in US\$	N/A				
Savings:	No				
Energy sale income in US\$:	No				
Comments:	---				
Pictures and grafics					

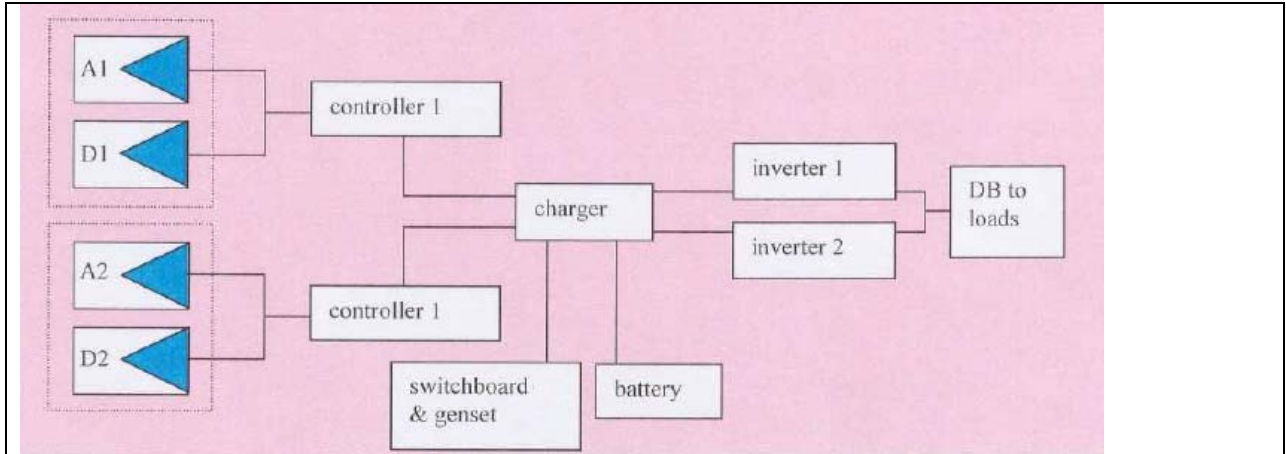

Wiring diagram of the hybrid system



Part of the NERC complex



Library



PV array



Genset and battery bank

Source: Asian Energy Awards 2004