

EIE-06-256 REEPRO

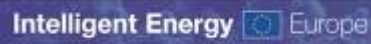

Promotion of the Efficient Use of Renewable Energies in Developing Countries

Practical works with PV training tool kit

Authors

Dr. Khamphone Nanthavong, NUOL

March 2008

List of Content

1	Objective and Toolkit description	1
2	Possible practical exercises with toolkit	2
2.1	Checking actual Module parameters	2
2.2	Modules connection	3
2.2.1	Connection of modules of the same size	4
2.2.2	Connecting modules of different size	5
2.3	Effect of Module orientation and slop	6
2.3.1	Study on the Effects of module orientation.....	6
2.4	Effects of Modules shading	7
2.5	Solar home system	9
2.5.1	Checking of Solar home system parameters	10
2.5.2	Solar home system trouble shooting and repair.....	10

1 Objective and Toolkit description

Objective: PV training toolkits are to provide better understanding and skills by exercising on real PV system.

Description: Each PV training toolkit comprises of two 10Wp solar modules, some connectors, and plugs, two multi-meters, contained in a case (figures 1.1-1.2).

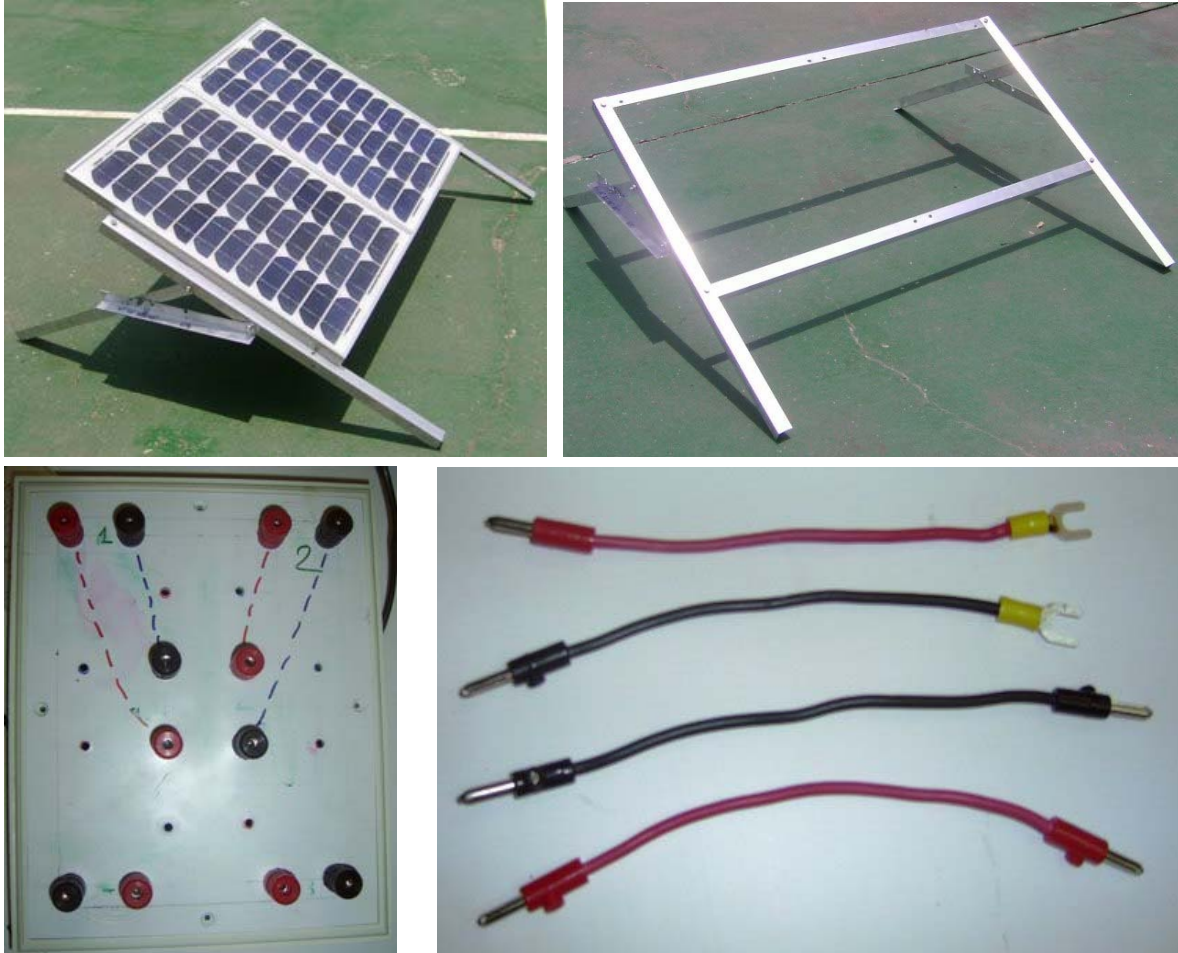

Figure 1.1 Mini SHS tool kit components



Figure 1.2 Multimeter (Max 10A at least)

Depending on real possibilities, the training kit can also include the following components

- Components of the real solar home system: charge controller, battery, some appliances (DC and AC), inverter , so that trainees can exercise on solar home system
- In order to practice or to demonstrate effects of connecting modules of different sizes, desirably a one kit with modules of other than 10Wp size, say 5 Wp or 15Wp would be needed.
- Furthermore, It would be nice if there is available one module with bypass diode so that the trainees can perform exercise on effect of shading of module with bypass diode.

2 Possible practical exercises with toolkit

2.1 Checking actual Module parameters

Objective of this exercise is to check the actual output parameters of solar module and then to compare with nominal ones

Performance: measurement of open circuit voltage (O.C.) and Short circuit current (S.C) of a given module and compare with its nominal parameters

Results are recorded down on the table 2.1

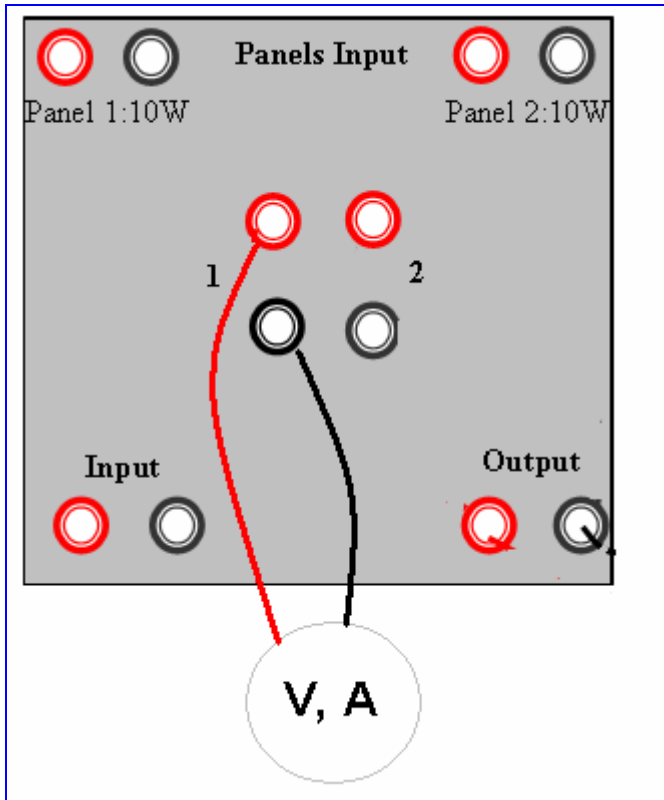

Figure 2.1 Checking of actual out parameters of the modules

Table 2.1 Comparison of actual and nominal output parameters of the modules

Modules	Nominal parameters			Actually measured parameters			Remarks
	$U_{o.c.}$ (V)	$I_{s.c.}$ (A)	P(Wp)	U (V)	I (A)	P (W)	
-Module 1							
Module 2							

2.2 Modules connection

Purpose of this exercise is to provide knowledge and skills on connecting modules to get desired system voltage, current and power.

The trainees are firstly to connect two 10Wp modules, then to connect modules of different sizes. For each connection, trainees should make measuring of the following parameter

- Open voltage ($U_{o.v.}$),
- short circuit current ($I_{s.c.}$)
- Calculate the output wattage($U_{o.v} \times I_{s.c.}$).

In this exercise, modules are placed at the same slop angle and orientation

The schematic diagrams of the exercises are shown in figure **Fehler! Verweisquelle konnte nicht gefunden werden.-2.5**

The table 2.2 shows what output data to be measured.–

Table 2.2 measured parameters

Connection	$U_{o.c.}$ (V)	$I_{s.c.}$ (A)	P (W)	Remarks
–Module 1 (single)				
–Module 2 (single)				
Connected In series				
Connected in parallel				

2.2.1 Connection of modules of the same size

- Connected in series (Figure 2.2)
- Connected in parallel (2.3)

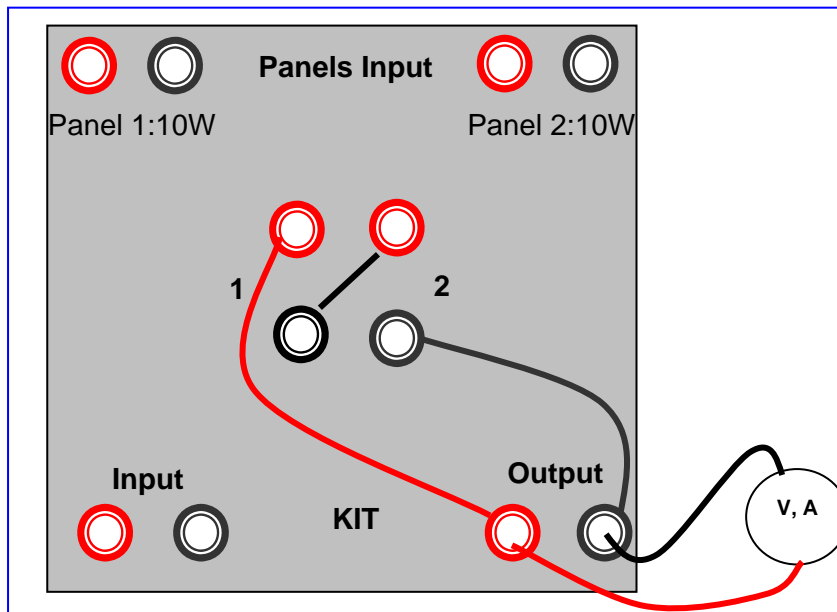

Figure 2.2 Modules in series

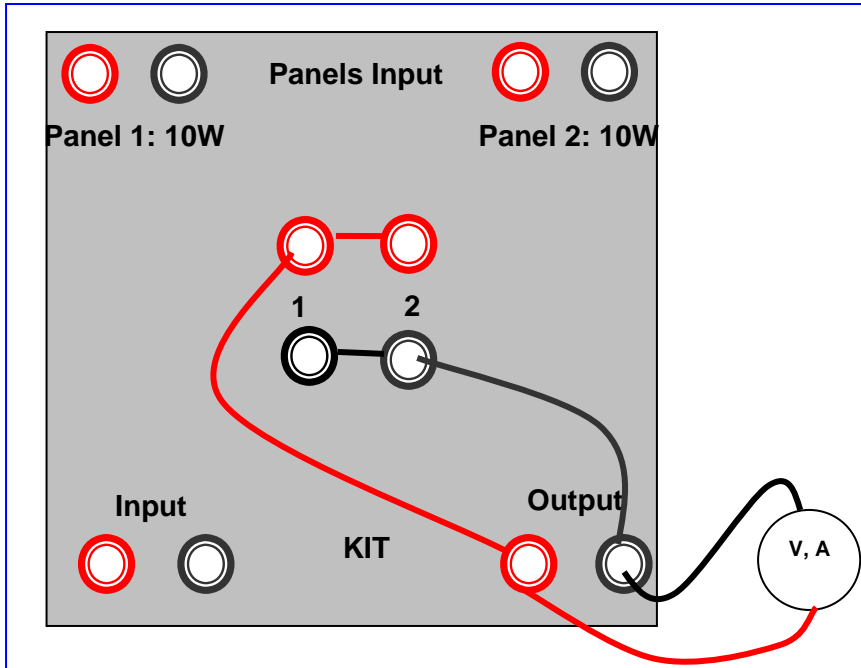

Figure 2.3 Connection of modules in parallel

2.2.2 Connecting modules of different size

- Connected in series (Figure 2.4)
- Connected in parallel (figure 2.5)

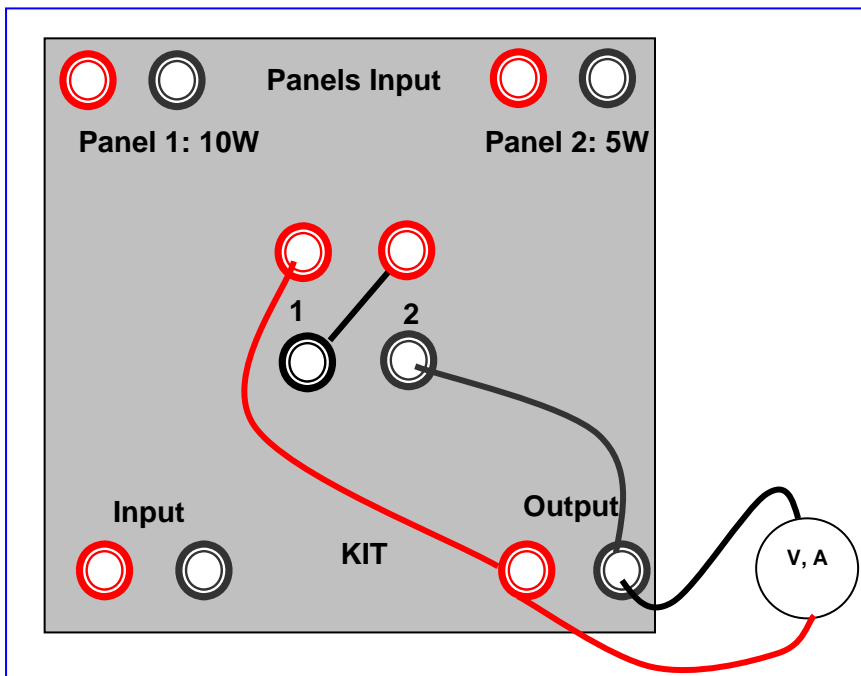

Figure 2.4 Modules of different size are connected in series

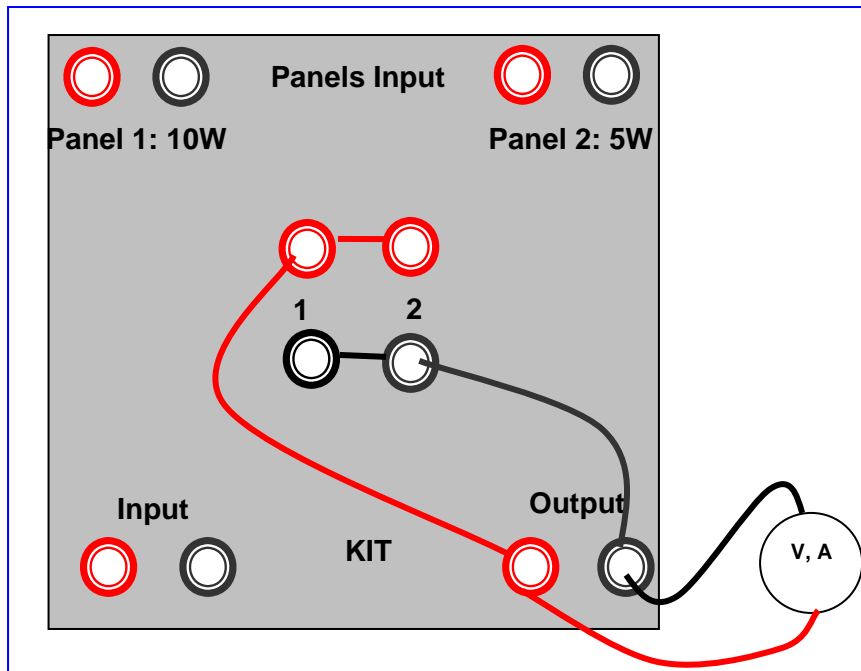

Figure 2.5 Different size modules are connected in parallel

2.3 Effect of Module orientation and slop

In this exercise, the modules of the same size are placed at different orientations and slops. Here either serial or parallel connection of the modules can be used.

For the study of the slops, the module is placed towards current position of the sun and then changing the slop angles 60, 40, 30, 20 –and10. Measured parameters are recorded down on table 2.3

Table 2.3 Effects of the slop angles of the modules

Slops	$U_{o,v}$ (V)	$I_{s,c}$ (A)	P (W)	Remarks
60				
40				
30				
20				
10				

2.3.1 Study on the Effects of module orientation

In this exercise, module is placed appropriately (say 30 degrees) and three positions of it can be studied: (1) the module facing current position of the Sun (in real SHS- facing south),

(2) facing to the left of current opposition (in real SHS: facing South-easterly orientation) and
(3) facing to the right of the current position of the Sun (Facing south – westerly). Measured parameters are put in table 2.4

Table 2.4 Effects of the module orientation

Orientation	$U_{o,v}$ (V)	$I_{s,c}$ (A)	P (W)	Remarks
Current position of the Sun				
Facing to the left of current position				
Facing to the right of current position				

2.4 Effects of Modules shading

Exercises on this topic would be:

- Partial shading of module with no by-pass diode: one module is used in this exercise

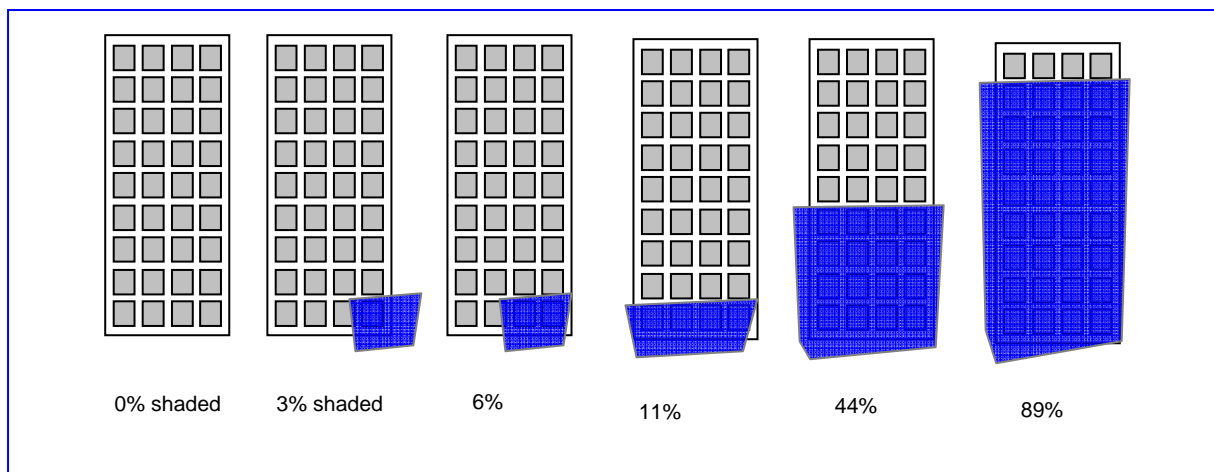

Figure 2.6: Exercises on module shading

- The exercises on shading of module with bypass diode can be carried out if the modules with by-pass (at least one module) will be available

Table 1 Measurements for module shading

Exercise	U (V)	I (A)	P (W)	% reduced of power as compared to no shading
No cells shaded (0% shading)				
One cell shaded (~ 3% shading)				

Two cells shaded (~ 6% shading)				
Four cells shaded (~ 11% shading)				
Eight cells shaded (~ 22% shading)				
Sixteen cells shaded (~ 44% shading)				
Thirty two cells shaded (~ 89% shading)				

- Modules array shading: two modules (with no bypass diode) are connected in parallel

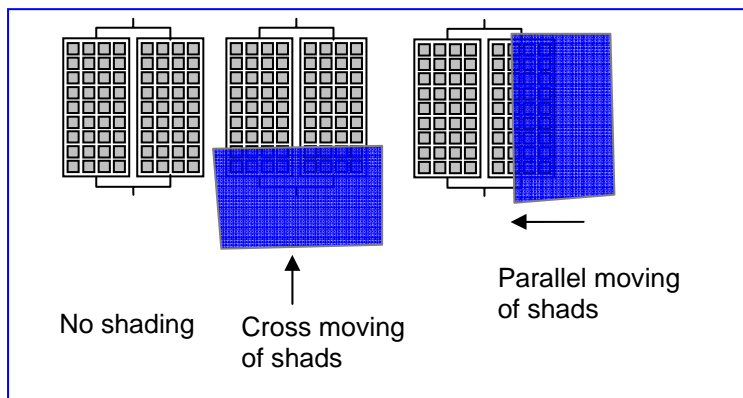

Figure 2.7 Modules array shading schematic_Khamphone

Table 2 Measurements for modules array shading

Exercise	U (V)	I (A)	P (W)	% reduced of power as compared to no shading
Crossly moving shade				
No shade (0% shading)				
First line of cells (11% shading)				
Lines 1-2 (22% shading)				
Lines 1-2-3 (33%% shading)				
Lines 1-2-3-4 (44% shading)				
Lines 1-2-3-4-5 (56% shading)				
Parallel moving shade				

No shades (0% shading)				
First line of cells (~13% shading)				
Lines 1-2 (25% shading)				
Lines 1-2-3 (38% shading)				
First module (50% shading)				
The first + 1 line of the second module are shaded (63%)				

2.5 Solar home system

In this exercise, trainees have opportunity to do sizing the solar home system. The SHS sizing procedures are described as followed:

- Daily energy demand for 1 DC lamp, AC TV and DVD player
- PV array sizing
- Battery sizing
- Controller sizing
- Inverter sizing

The Appliances of our SHS include 1 DC lamp; 1 AC TV; 1 DVD player;

PV generator for the solar home systems can be formed from several training kits, each of them has two 10Wp modules.

Connection of solar home system components depends on type of charging controller used, which may require specific procedure.

Usually connection of solar home system is performed by the following steps:

- (1) Battery to charging controller
- (2) Modules to charging controller
- (3) Appliances to charging controller (Note: all switches must be in “off” position, including inverter)

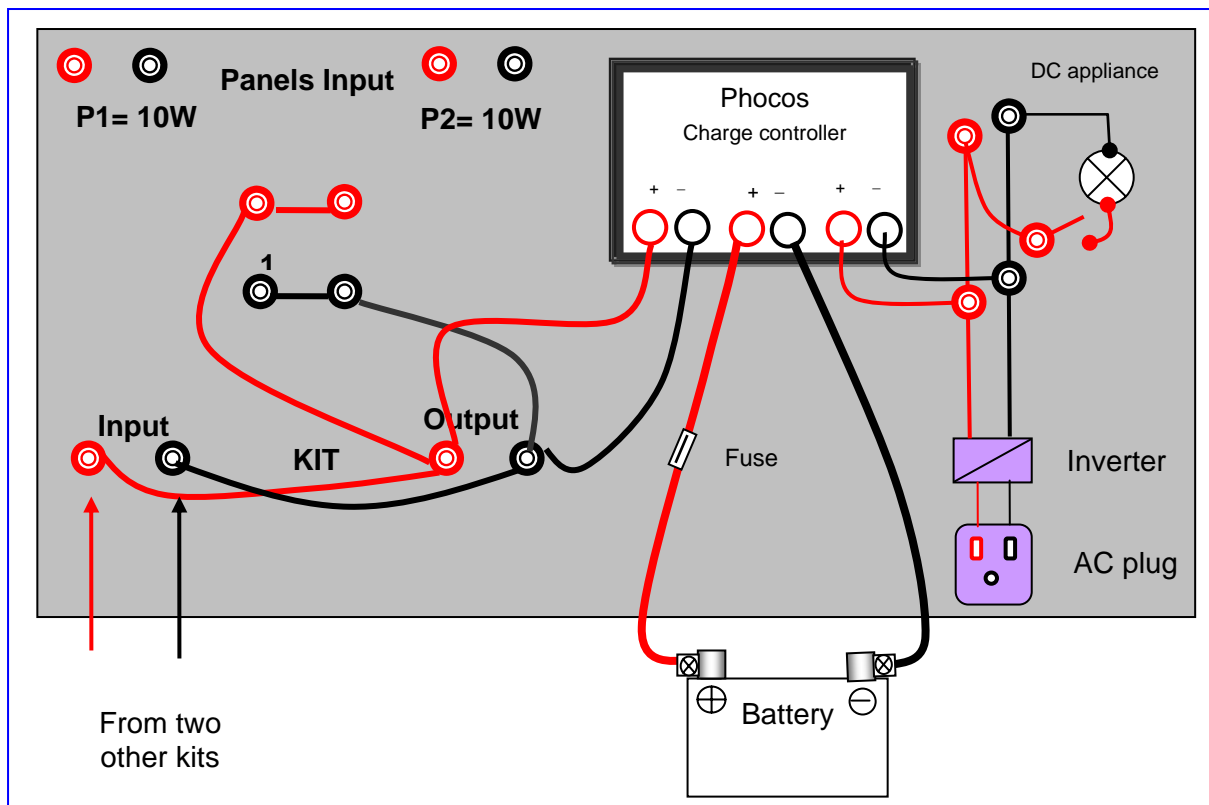

Figure 2.8 Tool kit box with typical Solar home system components _KN

2.5.1 Checking of Solar home system parameters

The Following characteristics of the solar home systems can be checked (measured):

- Operating voltage and current of the modules (the battery has already been connected and is charging)
- Operating voltage of the battery
- Input and Output voltage of the inverter

Note: Do not measure current (amperes) of the battery without any loads connected!

2.5.2 Solar home system trouble shooting and repair

With the kits, trainees can also do trouble shooting of solar systems, such cases as

- No charging current: completely loosed module contact, module failures, etc)
- Low charging voltage/current (due to loosed contact, modules shading, wrong orientation/slop, etc)
- Appliances not work (some or all)
- etc

Reference

1. PV_Training_Manual_Unesco_TTM_Full_UNESCO_2000

